

## Checkweigher System

Model RWG Series

### // PRODUCT HIGHLIGHTS

- **Superior Performance**—Inline check weighing for packaged products; lowers product waste/loss and improves efficiency
- **Quick and Accurate**—Self-controlled operation; unique signal processing and auto-zeroing technology ensures product weighing accuracy even with seafood or marinated products
- **Flexible**—Suitable for packaged products of all sizes
- **Reliable**—Stable design maintains accuracy without frequent calibration
- **Detection Integration**—Seamlessly pairs with metal detectors for a complete product inspection system
- **Advanced Features**—Quick product switching, robust data collection and analysis, multi-language operator controls and more



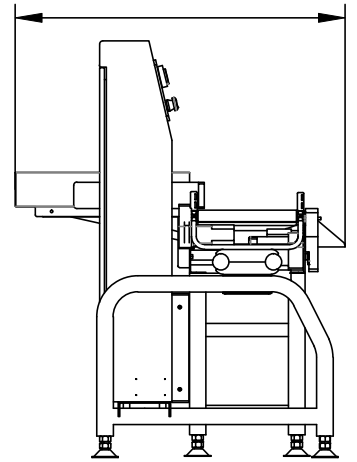
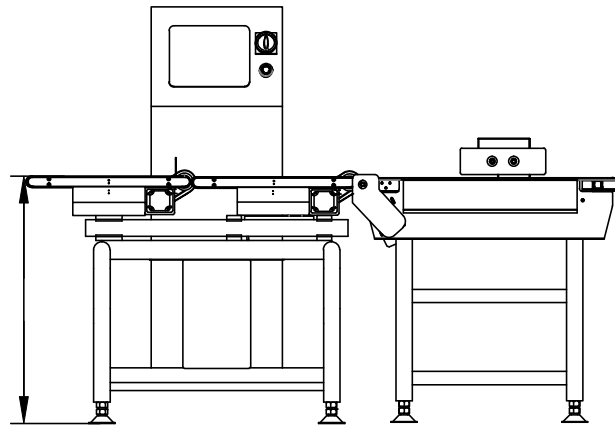

| Model                       |          | RWG-160                   | RWG-230S    | RWG-230L    | RWG-300     |
|-----------------------------|----------|---------------------------|-------------|-------------|-------------|
| <b>Detect Range</b>         |          | 10-600g                   | 20-2000g    | 20-2000g    | 20-5000g    |
| <b>Max Accuracy (3σ)</b>    |          | ±0.1g                     | ±0.2g       | ±0.2g       | ±0.5g       |
| <b>Max Detect Speed</b>     |          | 250 pcs/min               | 200 pcs/min | 155 pcs/min | 140 pcs/min |
| <b>Operator Interface</b>   |          | 10-inch LCD touch screen  |             |             |             |
| <b>Maximum Product Size</b> | <b>W</b> | 150mm                     | 220mm       | 220mm       | 290mm       |
|                             | <b>L</b> | 200mm                     | 250mm       | 350mm       | 400mm       |
| <b>Product Memory</b>       |          | 100 programs              |             |             |             |
| <b>Conveyor Segments</b>    |          | 2 or 3                    |             |             |             |
| <b>Belt Speed</b>           |          | 70m/min                   |             |             |             |
| <b>Weigh Platform Size</b>  | <b>W</b> | 160mm                     | 230mm       | 230mm       | 300mm       |
|                             | <b>L</b> | 270mm                     | 350mm       | 450mm       | 500mm       |
| <b>Rejecter Mode</b>        |          | Auto reject               |             |             |             |
| <b>Power Supply</b>         |          | AC110V                    |             |             |             |
| <b>Working Environment</b>  |          | Temperature: 32-104°F     |             |             |             |
|                             |          | Humidity: 30-85% (no dew) |             |             |             |



974 Corporate Woods Parkway, Vernon Hills, IL 60061, USA  
**tdipacksys.com**  
 P 877.TDI.6750 • F 847.620.0676 • sales@tdipacksys.com

